

QUIET SERIES

The 150 Quiet Exhaust Fan is a high quality, low noise axial wall/ceiling exhaust fan that can be connected to ducting. The fan is IP45 rated, has two selectable speeds and comes with a built in draft stopper. The unit also has built in anti-vibration components.

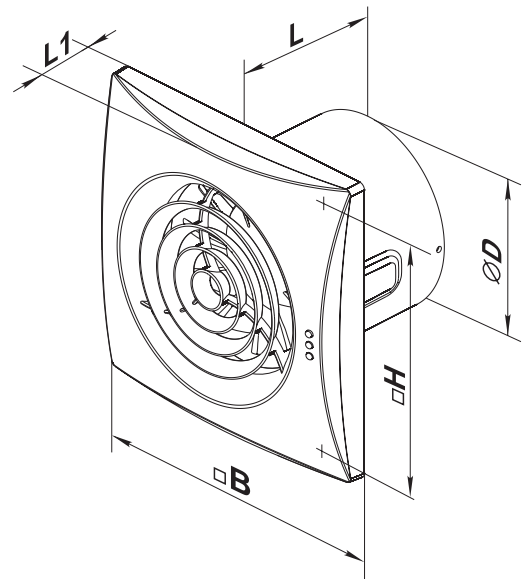
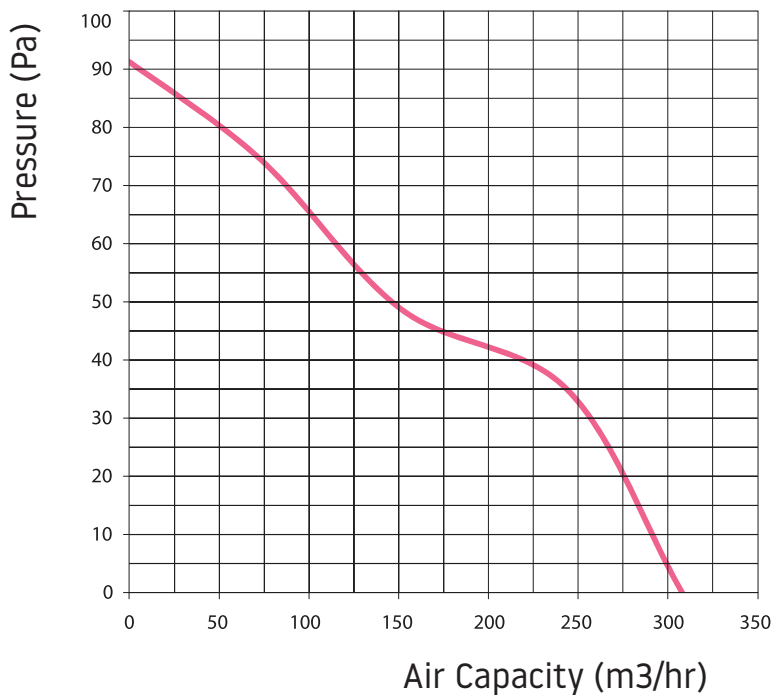

SKU	EMVUQT3
Voltage	230
Power (W)	19
Current (A)	0.09
Capacity (m ³ /hr)	315
Capacity (l/s)	87.57
Capacity (CFM)	185.53
Noise Level at 3m (dBA)	33
Protection rating	IP45

DIMENSIONS

SKU	EMVUQT3
D	148
B	214
L	111
L1	32
H	190