

# Habitat Series

Remote Control

EC Motor

2 Year

Two year replacement warranty

A decentralised heat recovery unit designed to supply & extract. Powered by an EC motor & highly efficient ceramic core heat accumulator.

fancoo

## Habitat Expert - EWVUEX1

Includes remote control + control on unit

## Habitat Expert WIFI - EWVUEX2WIFI

SMART compatible, remote & control on unit



	Expert			Expert Wifi			
	Speed 1	Speed 2	Speed 3	Speed 1	Speed 2	Speed 3	Boost
Extraction Rate (m3/hr)	15	30	50	18	30	58	108
Recovery Mode (m3/hr)	6	15	25	9	15	29	54
Current (A)	0.025	0.030	0.039	0.037	0.046	0.071	0.151
Power (w)	3.61	4.15	5.2	3.2	4.0	6.6	18.0
Sound Level (dBA)	11	18	21	13	18	30	42
Sound pressure attenuation (dBA)	42			42			
Max Units for System	10			Unlimited**			
Regenerating Efficiency	Up to 93%			Up to 87%			
IP Rating	IP24			IP24			
Included Filter Class	G3			G3			
Optional Filter Class	F8			F8			
Weight (kg)	9			9			

Sound level measured at 3m distance & based on operating at max extraction. Expert Wifi model features a 'boost' mode to provide more intensive ventilation.

\*\*Unit can be connected to a router and then to as many connection points as the router allows. Without router, this unit connects to mobile app and up to seven additional units

## Dimensions (mm)

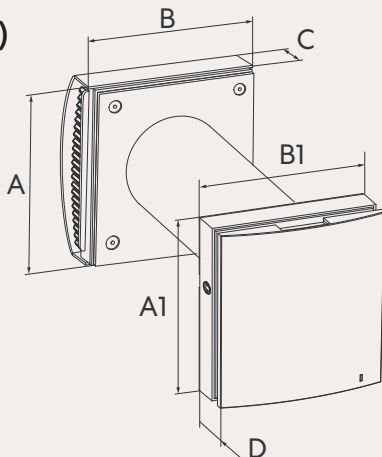

	Expert	Expert Wifi
A	284	231
B	280	220
A1	284	285
B1	234	235
C	137	54
D	64	68
Wall Thickness	240-500	335-500

# What's Inside

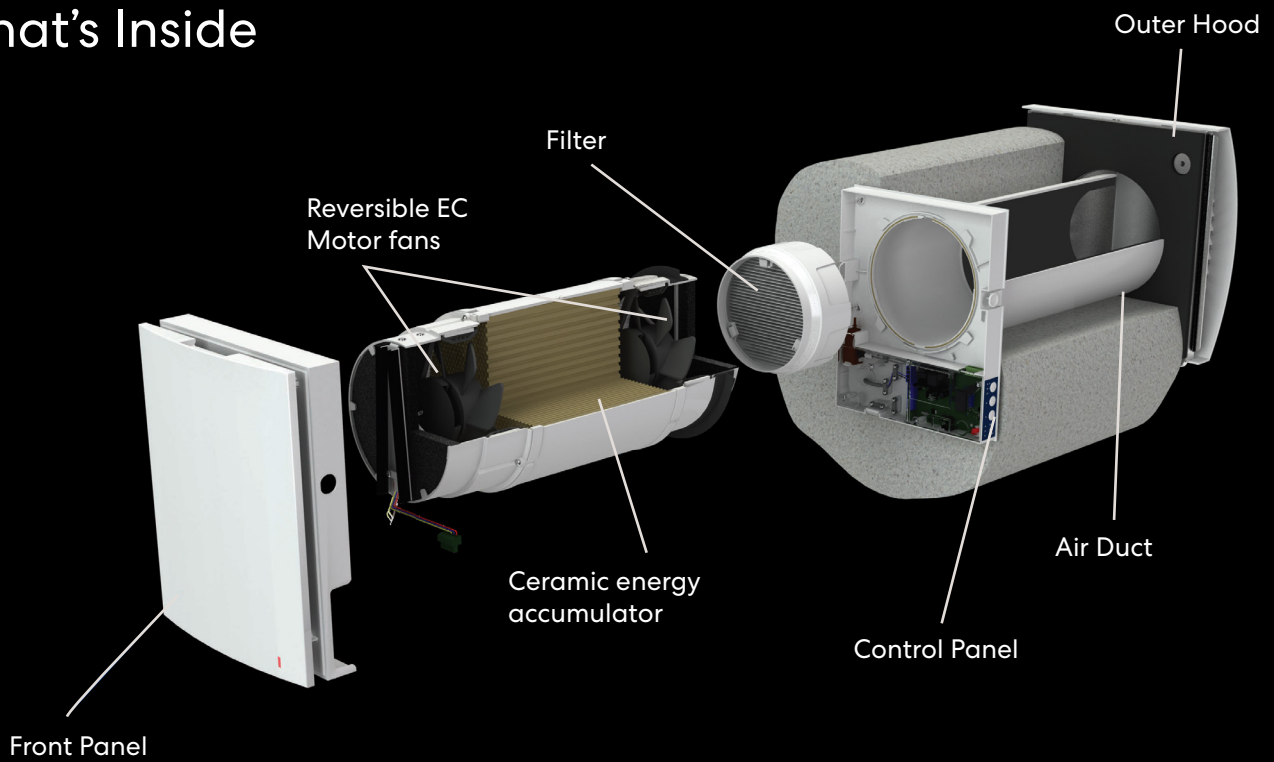

## Operation Logic

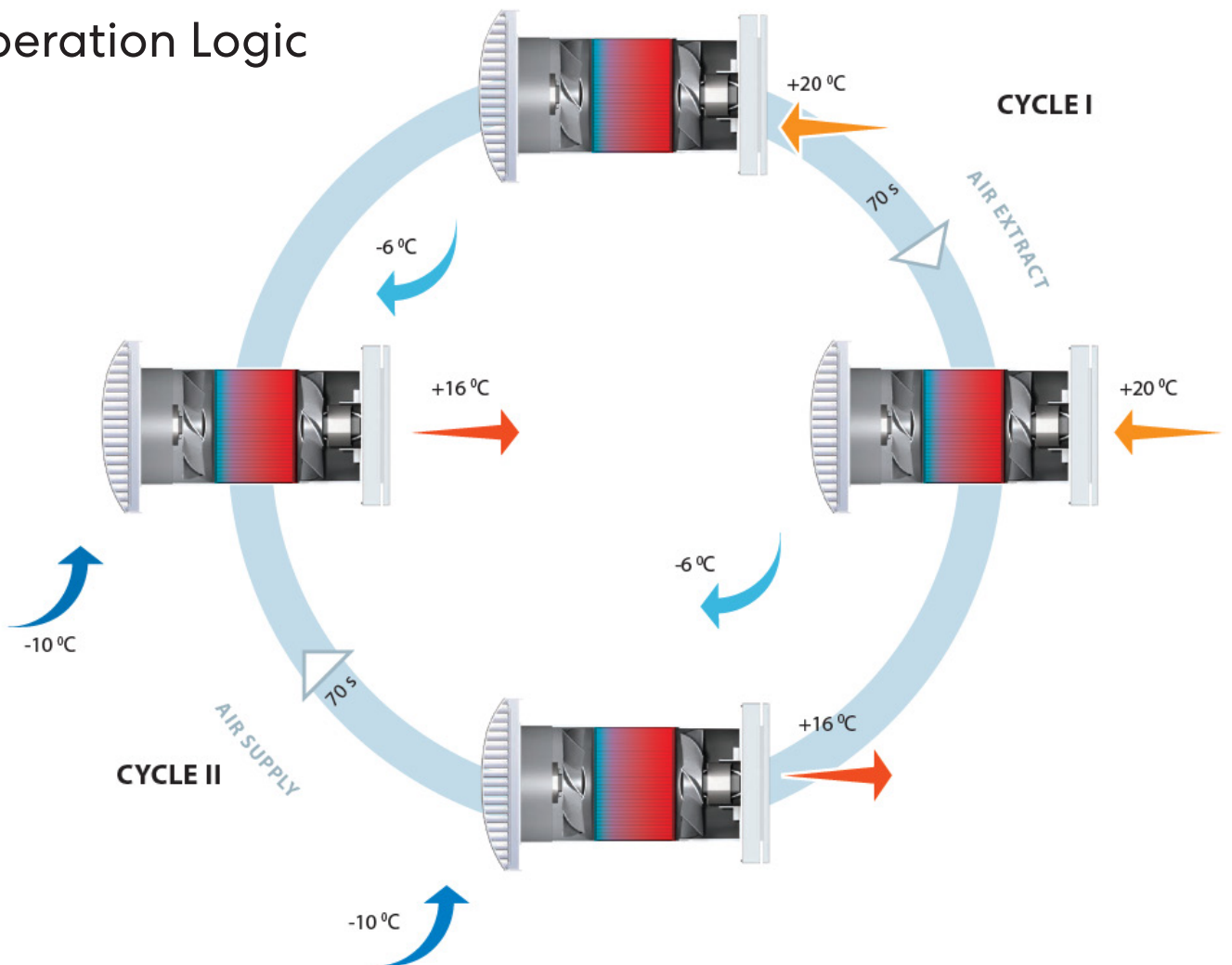

Decentralised heat recovery units are designed to **extract** and **supply**. In the first cycle warm, stale air is extracted from the room. As the warm air passes through the ceramic element, this component gets heated. The unit then commences cycle 2, clean air from the outside passes through the ceramic element, which heats the air before it enters the living space.

For more information visit [www.fancoo.com.au](http://www.fancoo.com.au)

**fancoo**