

Quiet 150 Series

The Quiet 150 is a ceiling or wall mounted exhaust fan which has been specifically engineered to operate quietly.

IP45
Rated

Low
Noise

Ceiling
or
Wall

2
Year

2 year
replacement
warranty

fanco

Quiet 150: EMVUQT3

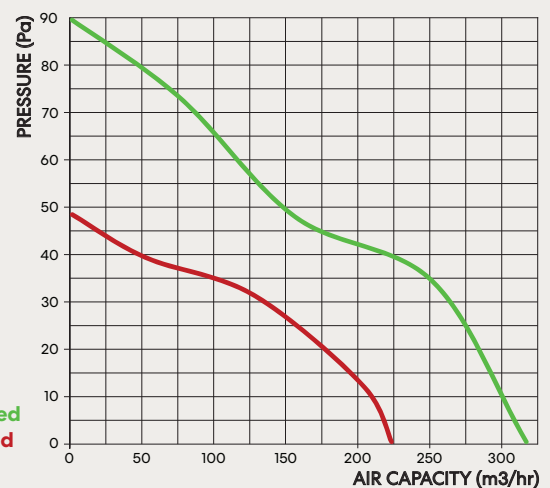

	Low	High
Voltage	230	230
Current (A)	0.08	0.09
Power (w)	17	19
Noise Level dB(A)	28	33
Capacity (m3/hr)	220	315
Capacity (l/s)	61.11	87.5
Capacity (CFM)	129.48	185.40
Duct Size (mm)	150	150

The Quiet 150 is a ceiling or wall mounted exhaust fan which has been specifically engineered to operate quietly. The unit has a capacity of 315m3/hr, it is a two speed motor and on the low speed the unit has a capacity of 220m3/hr. The desired capacity is achieved by wiring the fan to the relevant speed setting. This fan is relatively unique as it has anti vibration technology which helps to further reduce noise generated from the motor.

Dimensions (mm)

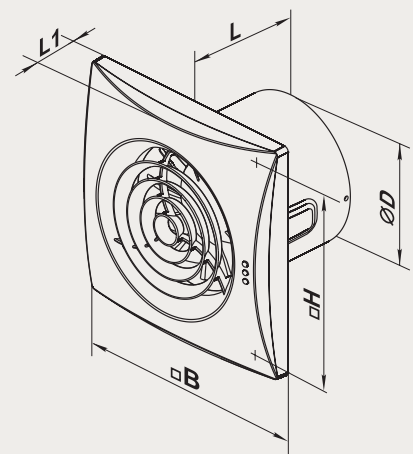

Model	D	B	L	L1	H
150	147.5	214	111	32	190